



## EMS-81X Compact Passive Loudspeaker User Manual – v1.0



### **EM Acoustics Loudspeakers**

Building 74, Dunsfold Park  
Cranleigh, Surrey  
GU6 8TB, UK

Phone +44 (0) 1483 266520

Fax +44 (0) 1483 275619

[www.emacoustics.co.uk](http://www.emacoustics.co.uk)

---

Copyright EM Acoustics 2012

1

**EMS-81X User Manual**

[www.emacoustics.co.uk](http://www.emacoustics.co.uk)

## CONTENTS

### Introduction

Thank you .....	3
Unpacking .....	3
Declaration of Conformity .....	3

### Product Overview

EMS-81X passive two-way enclosure .....	4
---	---

### System Set-up

Safety Considerations.....	5
Cabling & Amplifier selection .....	6
Protective DSP Settings .....	7

### Mounting & Rigging Options

Rigging Hardware & Accessories .....	8
Permanent Installations .....	8
Flying hardware Use.....	9
Omnimount/Powerdrive Installation hardware use .....	10

### Maintenance

EMS-81X Drive Unit Service .....	11
----------------------------------	----

Warranty .....	12
----------------	----

Appendix A – Technical Specifications .....	13
---	----

## INTRODUCTION

### Thank you

Thank you for purchasing a product from the acclaimed EMS Series from EM Acoustics. The EMS Series products have been carefully designed and rigorously tested to ensure years of flawless operation and unprecedented sonic quality. Flexibility is the key factor with EMS products, and consequently they are at home within a wide variety of applications from live and portable applications, through to cafes, bars, nightclubs, theatres and conference centres.

Please ensure that you read this manual carefully before use, and that you keep it to hand should you need it for further reference. Furthermore, should you have any difficulties please do not hesitate in contacting your EM Acoustics dealer, or email [info@emacoustics.co.uk](mailto:info@emacoustics.co.uk) for further assistance.

### Unpacking

Every EM Acoustics product is built to the highest standard and thoroughly tested before it leaves our factory. After unpacking your loudspeaker, please inspect it carefully for any signs of transit damage. If such damage is found, please notify the carrier at once to instigate a claim. It is suggested that you retain all packaging for future re-shipment.

## DECLARATION OF CONFORMITY



The products contained within this manual conform to the requirements of the EMC Directive 89/336/EEC, amended by 92/31/EEC and to the requirements of the Low Voltage Directive 73/23/EEC amended by 93/68/EEC.

Standards Applied:	EMC Emission	EN55103-1:1996
	Immunity	EN55103-2:1996
	Electrical Safety	EN60065:1993

## RECYCLING



This product and its packaging constitute the applicable product according to the WEEE directive. Please ensure that at the end of the working life of this product, it is disposed of sensibly in accordance with local and national recycling regulations. The packaging supplied with this product is recyclable. Please retain all packaging, however if disposing of this packaging please ensure that you comply with local recycling regulations. These products also all comply to the RoHS Directive 2002/95/EC.

## PRODUCT OVERVIEW

### EMS-81X compact passive loudspeaker



The EMS-81X is a compact, versatile, passive loudspeaker product designed for a wide variety of compact and discreet sound reinforcement applications. It features a high-power 8" (203mm) neodymium LF drive unit in a reflex enclosure, and a 1.7" diaphragm, 1" (25mm) exit neodymium high frequency compression drive unit coupled to a 90° x 60° rotatable waveguide. These components are matched by an internal passive crossover network for unprecedented sonic quality from a completely passive enclosure.

Due to its discreet size and appearance, the EMS-81X can be used in a wide variety of applications ranging from fills and delays in corporate and theatre use, to compact front of house and floor monitoring duty.

As with all EM Acoustics full-range products, no active controller or programmed EQ is required for correct operation. For demanding applications, a 70Hz, 24dB/octave high pass filter is recommended to increase drive unit headroom however this is not essential for normal operation – please see page 7 for further information.

The EMS-81X is supplied as standard in black or white, and is fitted with two Neutrik SpeakON™ NL4MP connectors. Custom colours, weather protection and specific connectors can also be supplied if required – please contact your local EM Acoustics representative for more details.

#### **To rotate the HF waveguide:**

1. Remove the front grille as described in the Maintenance section on Page 10 of this manual.
2. Using a 4mm Allen key, remove the four socket-head bolts retaining the HF waveguide in place.
3. Lift the waveguide up and rotate to the desired position – the label on the waveguide shows the dispersion orientation.
4. Reinstall the socket-head bolts and retighten. Avoid over-tightening as this may crack the waveguide.
5. Reinstall the grille as described in the Maintenance section on Page 11.

## **SYSTEM SET-UP**

### Safety Considerations

Loudspeaker systems are potentially dangerous objects if used incorrectly. Please ensure that you read this section fully, and contact EM Acoustics or your local dealer should you be in any doubt over correct operation procedures.

Professional loudspeaker systems are capable of producing damage-inducing sound pressure levels, and hence care should be taken when setting your system up, particularly when it comes to loudspeaker placement within a venue. Damage to the ear can result from levels above 90dB under prolonged exposure.

### Stand Mounting

The EMS-81X can be mounted from a loudspeaker stand using the integral polemount adapter for a standard 35mm loudspeaker stand. When mounting in this way, please consider the following:

- Ensure your stand height is locked off and the tripod legs are positioned so as to be stable.
- Check the weight loading of your stands before attempting to mount the loudspeaker.
- Do not stack a second loudspeaker on top of the stand-mounted one.
- Ensure cables are run so as to leave enough slack to enable neat wiring, and thus reduce the risk of the speaker being pulled over. Loose cables should be covered or taped down wherever possible to reduce trip hazards.
- If stands are being used outdoors, it may be necessary to add ballast to the base of the stand to prevent it toppling over.
- When using poles on top of subwoofer systems, please observe similar precautions.

### Ground Stacking

- Ensure that the floor or stage surface can withstand the weight of the system.
- Wherever possible, avoid high stacks and use ratchet straps to secure loudspeakers together. Please also remember that vibrations from subwoofer systems can shake other loudspeakers out of place, which may present a toppling hazard. The use of ratchet straps and non-slip material is recommended to prevent this.

### Rigging and Suspension

There are a variety of different methods for suspending your EMS-81X enclosures – please see the detailed section on Page 8 for further information.

**WARNING: The overhead suspension of loudspeakers is a very serious issue with potentially lethal consequences should anything go wrong. Rigging should only be carried out by experienced**

**personnel following safe working practice. Should you be in any doubt whatsoever, please contact your local dealer who will be able to refer you to a suitable rigging company.**

### Cabling and Amplifier Selection

The EMS-81X is designed to be used with professional power amplifiers providing the following power outputs:

EMS-81X                      500W/channel **into eight ohms**

A small power amplifier working too hard is more likely to damage a loudspeaker than a large power amplifier working within its operating range!

It is good practice to use an amplifier equal to the program power rating of the loudspeaker – so as to retain sufficient headroom and good dynamic range. Care should be taken during operation to avoid amplifier clipping – as this can cause serious damage to your loudspeakers. If in doubt, please contact your dealer who will be happy to assist you in correct amplifier choice and setup.

### Cabling

The EMS-81X is supplied as standard with Neutrik SpeakON™ NL4 connectors, wired pin 1+/1-. It is recommended that the resistance of your cable is less than one tenth of the nominal system impedance. Given below are the recommended maximum cable lengths for different cross-sections and impedances.

<b>Conductor Cross Sectional Area</b>	<b>Maximum Recommended Cable Length</b>		
	<i>4 ohms</i>	<i>8 ohms</i>	<i>16 ohms</i>
1.0mm <sup>2</sup>	11m	22m	44m
1.5mm <sup>2</sup>	17m	34m	68m
2.0mm <sup>2</sup>	22m	44m	88m
2.5mm <sup>2</sup>	29m	58m	116m
4.0mm <sup>2</sup>	44m	88m	176m
6.0mm <sup>2</sup>	66m	132m	264m

Pins 2+/2- on the SpeakON™ connectors are wired together to allow link-through with 4-core cables.

## Protective DSP Settings

The EMS-81X requires no DSP program to function correctly. However, excessive low frequency information will cause the LF drive unit's excursion to increase, which can result in damage to your loudspeaker.

The higher you raise the high pass filter on an EMS-81X, the more headroom and overall sound pressure level output there is available. For most medium-to-high level applications, we would recommend a minimum of an 70Hz high pass filter with a 24dB/octave slope to sufficiently protect the loudspeaker. For higher SPL applications, we would recommend raising this filter – we would stress that the higher the filter, the safer the loudspeaker will be. If you are in any doubt over suitable settings for your EMS-81X, please don't hesitate to contact EM Acoustics or your local dealer for support and advice.

## MOUNTING & RIGGING OPTIONS

### Rigging Hardware & Accessories

The EMS-81X has four options for mounting and suspension, both for temporary use and permanent fixed installation.

The EMS-81X contains five M8 threaded fixing points around the enclosure, to enable suspension using **forged shoulder eyebolts** (minimum thread length 20mm) or the optional FC-81Xv vertical or FC-81Xh horizontal flying cradles. These fixings allow suspension in any orientation, with the extra point on the rear of the enclosure available for pull-back to obtain the desired rigging angle or as a secondary safety point.

The EMS-81X also has four M6 threaded fixings on the rear for use with Omnimount Series 30 or Powerdrive Series 75 installation mounting hardware.

With any suspension method, a second anchor point should be used as a safety.

**Under no circumstances should the mounting points of one enclosure be used to suspend another enclosure below it. EM Acoustics are in no way responsible for the failure of incorrectly rigged systems. This information relates specifically to the rigging techniques for the EMS-81X enclosure only. If you are in any doubt about safe practices for rigging loudspeakers, please contact your local EM Acoustics dealer who will be able to advise you.**

### Permanent Installations

Any installation (permanent or temporary) must be securely attached to the structure of the building using chain, steel wire or web straps that are certified and load rated for the loudspeaker system. Consideration must be taken when determining the loading on the structure to include loudspeakers and rigging hardware, and the appropriate safety factor can then be decided upon. **If you are in any doubt whatsoever**, please contact your EM Acoustics dealer who will be able to refer you to an experienced rigging company. A reputable rigging organisation should also be able to advise on legislation regarding safety factors for suspended systems of this type.

### Safety Considerations

When utilising any suspension method, a secondary safety must be used. For any suspension method, fit an M8 eyebolt to any of the rigging points. A safety steel can then be attached to this and connected to your safety point. **If you are in any doubt whatsoever about how to safely suspend your loudspeakers, do not hesitate to contact your EM Acoustics representative who will be able to refer you to a qualified rigging company for advice.**



### Attachment of the FC-81Xv vertical flying cradle

Using the supplied M8 hexagon head bolts, align the mounting holes in the inner yoke with the mounting points on the top or the bottom of the enclosure. Ensure that both the flat and spring washers are used – the flat washer should be in contact with the cradle. Tighten the bolts to ensure a solid fit. Once the desired angle of the loudspeaker is set, tighten the knobs on the cradle to lock the position in place. The bracket allows for complete rotation of the loudspeaker if required. The points on the top of the flying cradle can be used for permanent installations or to secure a hook clamp. Ensure that an M8 eyebolt is secured to the rear point on the EMS-81X enclosure to use as a secondary safety.

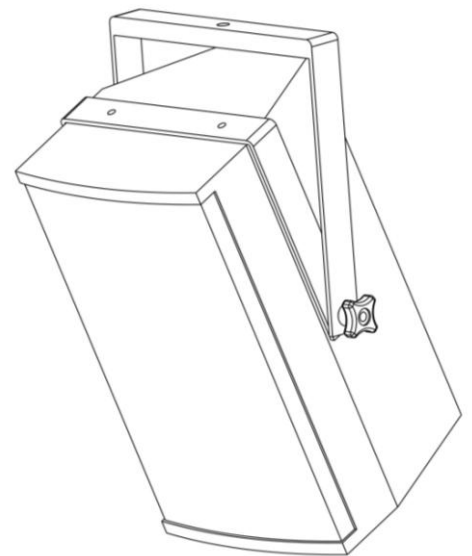

### Attachment of the FC-81Xh horizontal flying cradle

Using the supplied M8 countersunk socket head bolts, align the mounting holes in the end mounts of the yoke with the mounting points on the top and the bottom of the enclosure. Tighten the bolts to ensure a solid fit. Once the desired angle of the loudspeaker is set, tighten the knobs on the cradle to lock the position in place. The bracket allows for complete rotation of the loudspeaker if required. The points on the top of the flying cradle can be used for permanent installations or to secure a hook clamp. Ensure that an M8 eyebolt is secured to the rear point on the EMS-81X enclosure to use as a secondary safety.

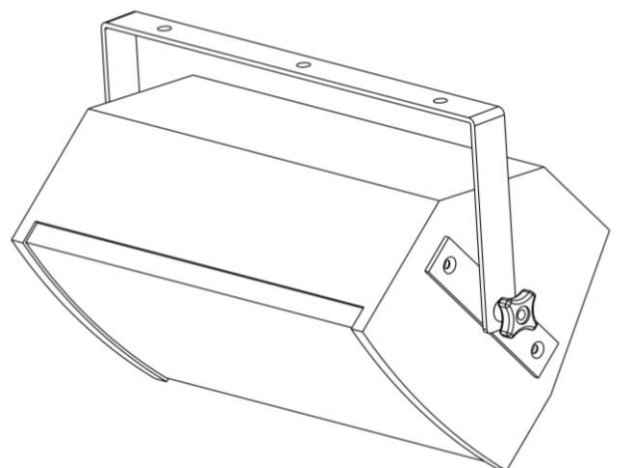

### Assembly of clusters using the DFB-81 flyplate set

Using the supplied M8 hexagon head bolts, bolt through the DFB-81 plate into the enclosure. Ensure that both the flat and spring washers are used – the flat washer should be in contact with the plate. Once the desired angles of the loudspeakers are set, tighten the bolts to lock in place. Then turn the cluster over and repeat the process on the bottom. Use the rear points on the EMS-81X enclosures, or the M10 holes on the DFB plates to use as a secondary safety.

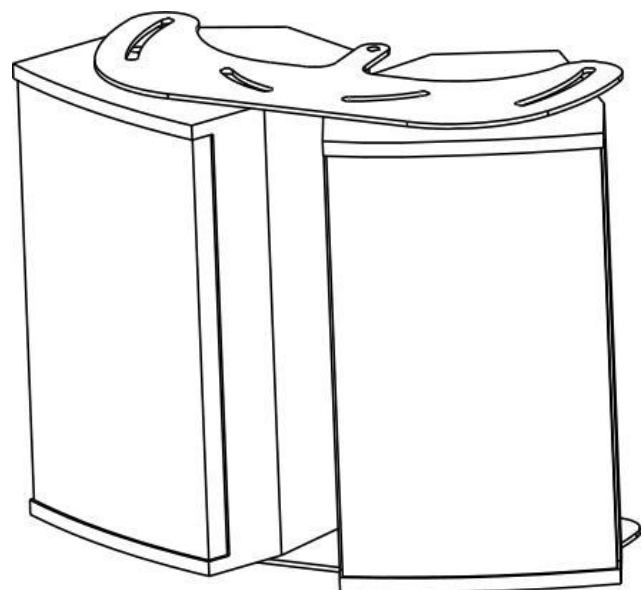

### Attachment of Omnimount™ or Powerdrive™ Installation Brackets

*It is strongly suggested that you position your loudspeakers, then mark & drill the holes in the mounting walls before you attach the bracket to the loudspeaker, as it is much easier to check positioning and fit of the holes without the weight of the loudspeaker.*

**The EMS-81X is designed to work with OmniMount™ Series 30 or PowerDrive™ Series 75 products.**

Lie the enclosure on its front and remove the four M6 countersunk points on the rear of the enclosure. Position the loudspeaker-side of the bracket as required, reinstate the bolts and retighten. The bracket and EMS-81X can now be mounted using the holes you have pre-drilled.

## MAINTENANCE

Your EM Acoustics loudspeakers have been rigorously tested before they leave our factory, to ensure that they give you a lifetime of flawless operation. Should any of your drive units fail and need replacing, please follow the guidelines below.

### EMS-81X: Low Frequency Drive Unit

1. Using a 3mm Allen key, undo the four M4 machine screws top & bottom of the enclosure (2 each end). Gently remove the grille from the front of the enclosure.
2. Using a 4mm Allen key, remove the eight M5 socket-head bolts holding the drive unit in place, and keep them safe – ensuring you have collected both the shake-proof and flat washers for each bolt. Gently lift the drive unit out of its locating hole – please take care as it is heavy! Carefully disconnect the cables from the drive unit.
3. To reinstate the driver, simply reverse the above procedure. Please observe the correct polarity – red cable to positive terminal, black cable to negative.
4. Reinststate the grille by gently placing it in place over the front of the loudspeaker. Replace the four M4 machine screws to secure it in place.

### EMS-81X: High Frequency Drive Unit

1. Follow the procedure above to remove the front grille.
2. Using a 4mm Allen key, remove the four M5 socket-head bolts holding the waveguide in place. Gently disconnect the cables from the drive unit and remove the unit from the enclosure.
3. To reinstate the drive unit, gently reconnect the cables (white cable to positive terminal, yellow cable to negative) and insert back into position. Note the waveguide orientation for correct dispersion. Replace the four bolts and gently tighten.
4. Reinststate the grille by gently placing it in place over the front of the loudspeaker. Replace the four M4 machine screws to secure it in place.

## **WARRANTY**

### Limited Warranty

This EM Acoustics loudspeaker product is warranted to the original end-user purchaser and all subsequent owners for a period of **three years** from the original date of purchase.

### Warranty Coverage

This warranty covers defects in materials and workmanship. It does not include:

- Damage or failure caused by accident, misuse, neglect, abuse or modification by any person other than an authorised EM Acoustics representative.
- Damage or failure caused by operating the loudspeaker product contrary to the instructions contained within this manual.
- Damage caused during shipment.
- Claims based on any misrepresentation by the seller.
- Products which contain anything other than the original components (or EM Acoustics factory supplied spare parts).
- Products on which the serial number has been removed, altered or defaced.

### Returning your EM Acoustics loudspeaker

Should your EM Acoustics loudspeaker develop a fault, please return it (freight prepaid) in its original packaging, along with proof of purchase to your local dealer or to:

**EM Acoustics (Returns Department), Building 74, Dunsfold Park, Cranleigh, Surrey, GU6 8TB, UK**

including a description of the suspected fault. Serial numbers must be quoted in all correspondence relating to the claim. EM Acoustics or its representatives are in no way liable for any loss or damage in transit, and hence it is recommended that the sender insure the shipment. EM Acoustics will pay for return freight should the repair be covered under warranty.

EM Acoustics' liability is to the replacement or repair (at our discretion) of any defective components, and as such are not liable for any incidental and consequential damages including (without limitation) injury to persons, damage to property or loss of use.

**This warranty is exclusive and no other warranty is expressed or implied. This warranty is also in addition to – and in no way detracts from – your statutory rights as a consumer.**

## APPENDIX A – TECHNICAL SPECIFICATIONS

EM Acoustics operates a continuous process of research and development, and as such reserves the right to alter specifications without notice.

### EMS-81X

<b>ENCLOSURE TYPE:</b>	two-way passive, reflex loaded
<b>DIMENSIONS (HxWxD):</b>	462 (18.2) x 262 (10.3) x 261 (10.3) mm/(ins)
<b>NET/SHIPPING WEIGHT:</b>	13/14kg (28.6/30.8lbs)
<b>FREQUENCY RESPONSE<sup>1</sup>:</b>	75Hz – 20kHz +/- 3dB
<b>SENSITIVITY<sup>2</sup>:</b>	95dB
<b>DISPERSION<sup>3</sup>:</b>	90 x 60, rotatable
<b>DRIVE UNITS:</b>	8" (203mm) LF cone drive unit 1" (25mm) exit neodymium HF compression drive unit
<b>POWER HANDLING:</b>	250W RMS, 500W program
<b>MAXIMUM SPL<sup>4</sup>:</b>	120dB continuous, 126dB peak
<b>NOMINAL IMPEDANCE:</b>	8 ohms
<b>CROSSOVER:</b>	asymmetric internal passive
<b>CONNECTORS:</b>	2 x Neutrik SpeakON™ NL4MP
<b>ENCLOSURE:</b>	15mm (5/8") multi-laminate Birch plywood – rebated, screwed & glued. Finished in impact resistant textured paint
<b>RIGGING &amp; HARDWARE:</b>	5 x M8 threaded mounting points 4 x M6 threaded points for OmniMount Series 30/Powerdrive Series 75 brackets 1 x flush handle on rear 1 x 35mm polemount socket
<b>GRILLE:</b>	hex punched steel backed with acoustically transparent foam
<b>OPTIONS:</b>	Colours/Weather Protection
<b>ACCESSORIES:</b>	FC-81Xv vertical flying cradle FC-81Xh horizontal flying cradle DFB-81X dual enclosure flying plate set
<b>SPARE PARTS:</b>	DU-802 8" drive unit CDU-1001A 1" exit HF compression drive unit RK-802 recone kit PX-81X passive crossover assembly RFG-81X replacement grille/foam

#### Notes on measurement conditions:

<sup>1</sup>Measured on-axis at 2m in an anechoic environment and referenced to 1m.

<sup>2</sup>Measured in half space at 2m with 4W sine wave input and referenced to 1m.

<sup>3</sup>Nominal dispersion, measured in an anechoic environment and averaged over stated bandwidth

<sup>4</sup>Calculated and verified by subjective listening test of familiar program material.